

The Art of *Economy*

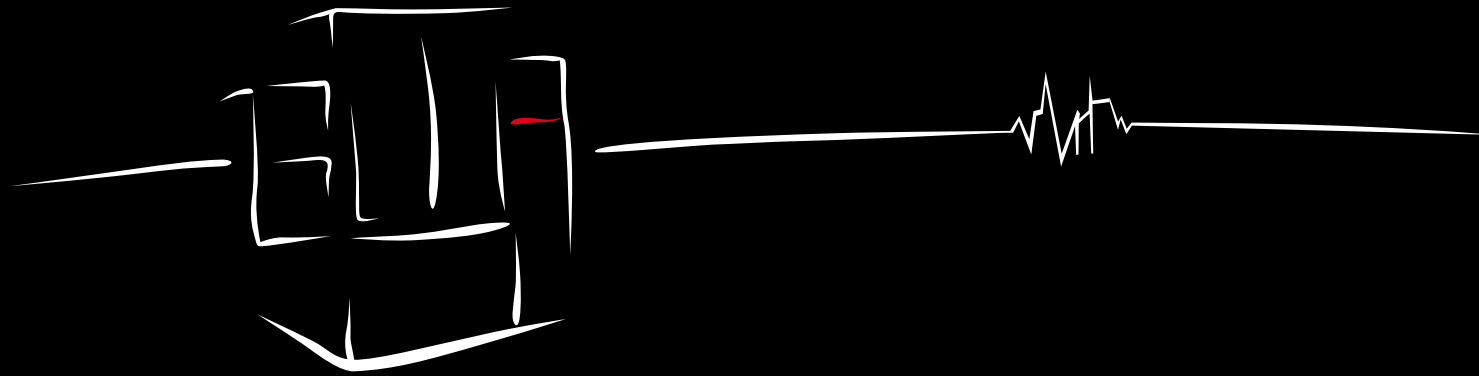

Die Sinking - Power for Production



EA-S



33 model series since 1964.

An assurance of dependability.

Mitsubishi Electric	5	Consumables	21
Highlights	7	All inclusive	23
Design	9	Optional extras and non-standard materials	25
Simple operation	11	Automation	27
Simple adjustments	13	Examples of applications	29
Intelligent user guidance	15	Service	31
Generator technology	17	Key data	33
Remote control	19	Technical data	35

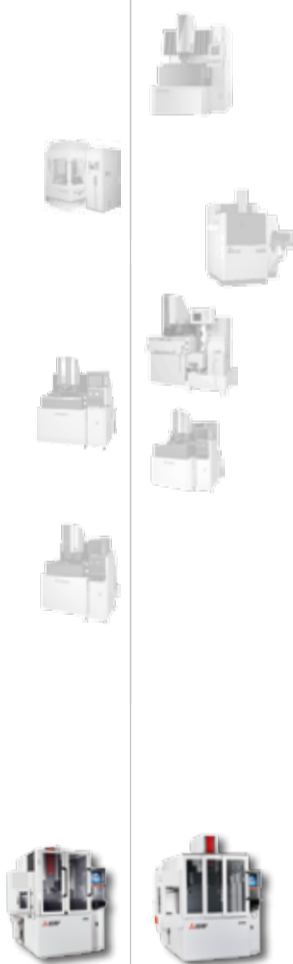

Over

7,000

patent applications
per year

63,000

produced wire-cut
EDM machines

125,000

employees

90 years

of dependable
technology



If you've got grand designs,
you need someone strong you can count on.



Since 1970, a growing number of European companies have therefore been turning to high-performance EDM machines from world market leader Mitsubishi Electric.

Only by producing components in-house is it possible to tailor them perfectly to the intended task. Mitsubishi Electric resorts to its own controls, semiconductors, motors and other items, which are adapted in detail to all requirements. The only thing you notice is that it works – and often for many decades after purchase.

If you want to invest soundly in a durable EDM machine, choose **Mitsubishi Electric**.

 EA-S

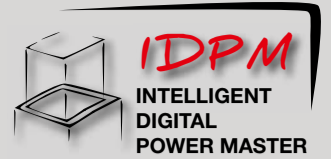

Significantly reduced graphite electrode wear achievable with enhanced erosion speed.

The Power Master of die sinking. The generator settings are attuned to minimal wear coupled with maximal machining speed in the ongoing process.

Continued on page 17



40% faster process

Up to 40% faster thanks to optimised axis motions especially for deep cavities. Swift lifting and lowering creates a flushing effect even in deep rib geometries. Everything for optimal results in difficult erosion situations – even in 3D.



Operation must be simple and assist the user.

Dialogue-supported programming guides each user intuitively to the desired goal. Experts also readily resort to column programming for quick and flexible adjustments. How to reach your goal.

Continued on page 11

80 A economy booster with an unparalleled price/performance ratio.

Up to 80% less graphite electrode wear

Solid, compact and with sufficient performance reserves when it matters – yet 20% more economical. The EA-S Series comes with the further-developed FP805 all-round generator, graphite technology and the new IDPM Power Master. High performance ex works.

The equipment giant among die-sinking erosion systems

A genuine all-rounder – with everything inclusive! An unbeatable price/performance ratio inclusive of electrode changer, automatic fire-extinguishing system and C-axis. This means you're equipped for all eventualities and enjoy maximum versatility plus impressive flexibility.

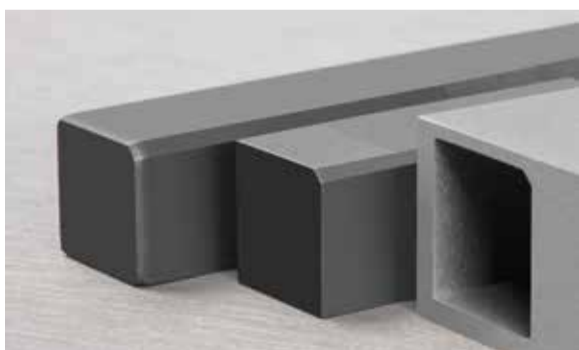

Minimal wear thanks to new graphite technology



Electrode changer of the EA8S model with ten magazine pockets



Set-up the easy way.

The three-sided elevating work tank clears the way – for easy access and simple loading. Graphic user guidance makes workpiece and electrode set-up child's play. Convenience that makes a difference.

Continued on page 15



An EDM system must help your company to make money.

The EA-S Series cuts expenditure on electricity, wire and filters considerably – so that you can earn more. The machine is designed for decades and has extra-low maintenance needs thanks to intelligent technologies.

Continued on page 21



Digs deep into the workpiece, not into your pocket.



Effective machine strategy.

Solid, compact and ergonomic.

Precise axis motions – whatever the loading

Thoroughly solid mechanical engineering, just the way it should be. Ingenious, tidy and absolutely durable. These principles have decades of success behind them and are cast in metal in each new machine. Inclusive of the use of high-grade axis components.

Ergonomic work space

Good accessibility due to the elevating work tank for convenient and swift set-up. The precision-ground work table at an ergonomic height is equipped with standard T grooves.

Compact and maintenance-friendly

The machine's compact and ingenious layout saves you space and time. Everything under control without long distances. Convenience that you will appreciate long-term.

Configured for performance

Only if you produce the all-important electronic components yourself, can you tailor them precisely to requirements. Mitsubishi Electric produces its own semiconductors and adapts them perfectly to actual needs. Obviously a clear advantage for you, the user.

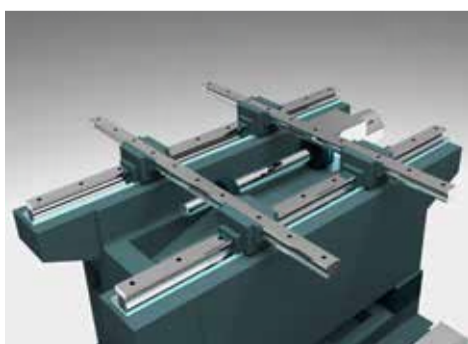



Simple touchscreen operation – like on a smartphone.

Sophisticated technology, simple operation – that's die sinking today.



Dialogue-guided programming

Machining programs are produced entirely with the aid of dialogue guidance – at Mitsubishi Electric by the name of “ESPERADVANCE Navigator”.

Plain-language selection windows guide the user from set-up via technology selection through to program start. Something that all users, from beginners to the advanced, will value.

Machining strategy easily produced

Ready for any task thanks to the comprehensive library in the control. Only the details of the task in question are still required, and from this the control automatically generates a complete machining program. From the chosen pair of materials for electrode and workpiece, the technology is automatically selected. Taking you quickly to your goal – for higher productivity and profits.

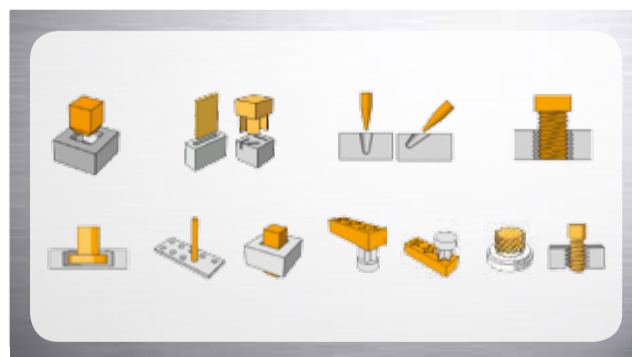



Optimisation and precise information – reaching your goal faster with column programming.



Column programming

After selection of the technology, all the key parameters are always available at a glance. Neatly laid out and easy to modify – even without menus. Programming multiple machinings or the multiple use of multiple electrodes is always a simple task.

Real-time information

Professionals want all the necessary data – the monitor gives them all the relevant information and additionally the chance to intervene in the current process. This way, they have everything comfortably under control throughout and achieve immaculate results every time.

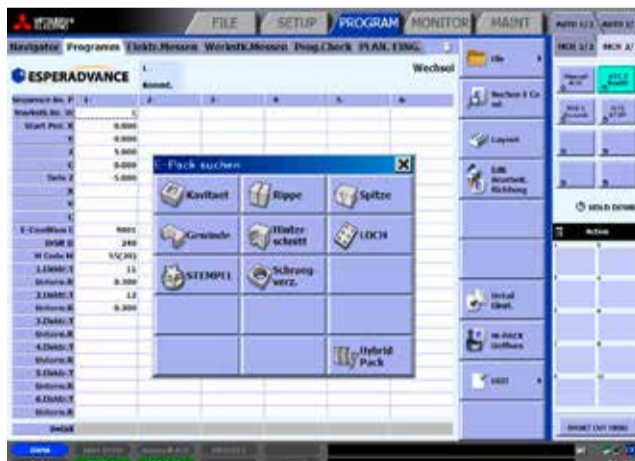

Everything at a glance: Direct access to individual settings

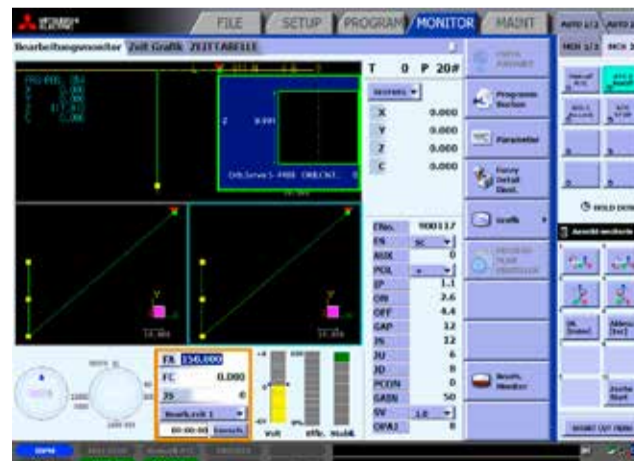

Overview as for the telemetry of the F1



Making my life easier.



Clamp it and press *Start!*

Set-up the easy way.



Electrode detection

Thanks to automatic and simple electrode position detection, you can work accurately, comfortably and quickly.

Workpiece detection

You can detect the position of the workpieces as comfortably as that of the electrodes.

... or perform external measurement

External presetting on a measuring machine is of course supported by the Mitsubishi Electric EA-S – for automated operation and maximum economy.

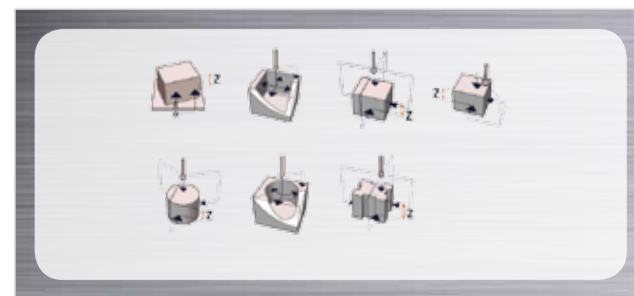
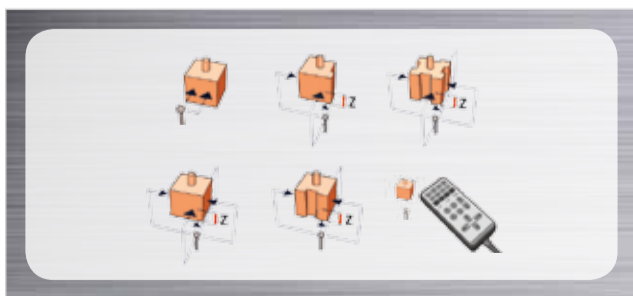



The generator.

Built to perform.



The FP80S generator is designed for a broad range of applications. Be it the machining of steel with copper or graphite electrodes or the machining of cemented carbide components – the generator technology is a match for any task.

80 A – with IDPM, the key to success

The Intelligent Digital Power Master (IDPM) is the key to the special performance attributes of the EA-S. Minimal graphite electrode wear with high erosion rates and high performance in the machining of cemented carbide – all courtesy of IDPM.

40% higher speed

Significant improvement over conventional machines: up to 40% higher machining speed is achievable with cemented carbide – thanks to the new IDPM. The erosion of cemented carbide is now more cost-effective than ever. An advantage that you will come to appreciate more and more.

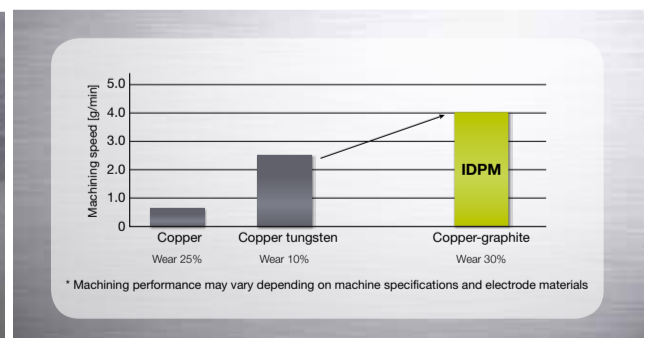

Remote control
with mcAnywhere



Always in charge – wherever you are.

You can control the machine and keep an eye on processes, wherever you are. Intelligent communication takes the pressure out of work. Ideal combined with automation solutions and high process autonomy with the intelligent AT wire threader.

mcAnywhere Control

Comfortable and reliable remote control for your EDM system – powered by TeamViewer.

mcAnywhere Service

Rapid help from Mitsubishi Electric experts.

mcAnywhere Contact

Any place, any time ... always up to date with direct status messages.



 EA-S

The freedom I expect.



Quick replacement, long-term savings.



Rapid filter change ...

... without tools or wasted time. Two hands, 32 seconds – and the filter is replaced.

Automatic central lubrication

Makes for smooth running long-term – entirely without stoppages, lubrication nipples or cumbersome grease guns. You can now make more productive use of this time.

What makes the EA-S so maintenance-friendly and economical?

The erosion systems from Mitsubishi Electric rank among the most dependable on the market. Thanks to their low maintenance needs and less downtime, you can't help economising – year after year.



Filter change in
32 seconds



Machine lubrication in
0 seconds



Now watch:
www.mitsubishi-edm.de/filters



While others are still setting up, you're already cutting.



Really? All inclusive?!

Sure!

Tool changer inclusive

Why buy expensive extras when they're already standard at Mitsubishi Electric? No installation, no extra effort, but a solution that works perfectly from the word go.

EA8S: 10 electrodes

EA12S: 20 electrodes

Inbuilt safety

Safety always comes first and therefore has to be integrated in the basic equipment so that you can even run your machine without supervision, if need be.

C-axis inclusive

The freely programmable precision C-axis that operates in simultaneous mode is part of the standard package. The axis can also be employed rotationally and equipped with all the conventional chucks such as EROWA ITS, Hirschmann System 4000, System 3R Macro/Combi (EROWA ITS is standard).





Customised extension.

The intelligent solution.

B-axis ITS-HV-100

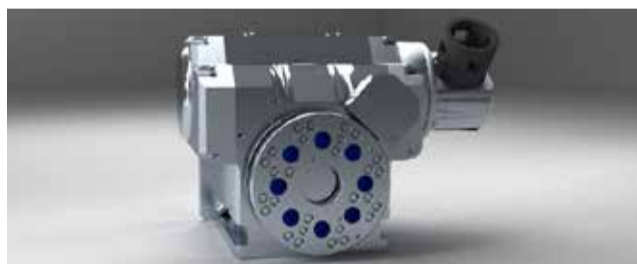

As an addition to the 4 standard axes, a further simultaneous axis can be integrated as a B-axis.

FP120S generator



On the EA12S the standard generator can be replaced with the more powerful 120 A generator of the FP120S type – if high performance is what counts.

Warning lamp



The three-stage LED warning lamp clearly indicates the machine status, making it visible from a distance – and it looks good as well.

ITS-MS-24 rotary spindle

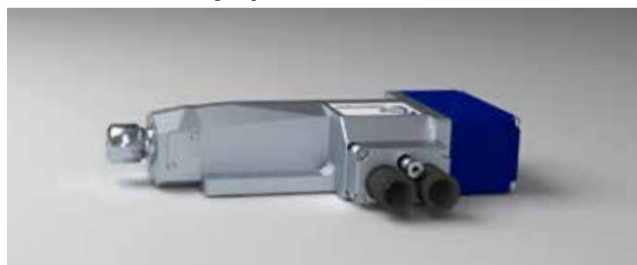

The rotary spindle can be integrated in the machine control – this way it can also function as an infeed axis or even operate in simultaneous mode.

Optional chuck (Hirschmann / System 3R)



Be it from EROWA, System 3R or Hirschmann, the chuck always fits. The standard C-axis interface is completely flexible.

ERGO-LUX



Additional ergonomic work space lighting – so everything is clearly visible.

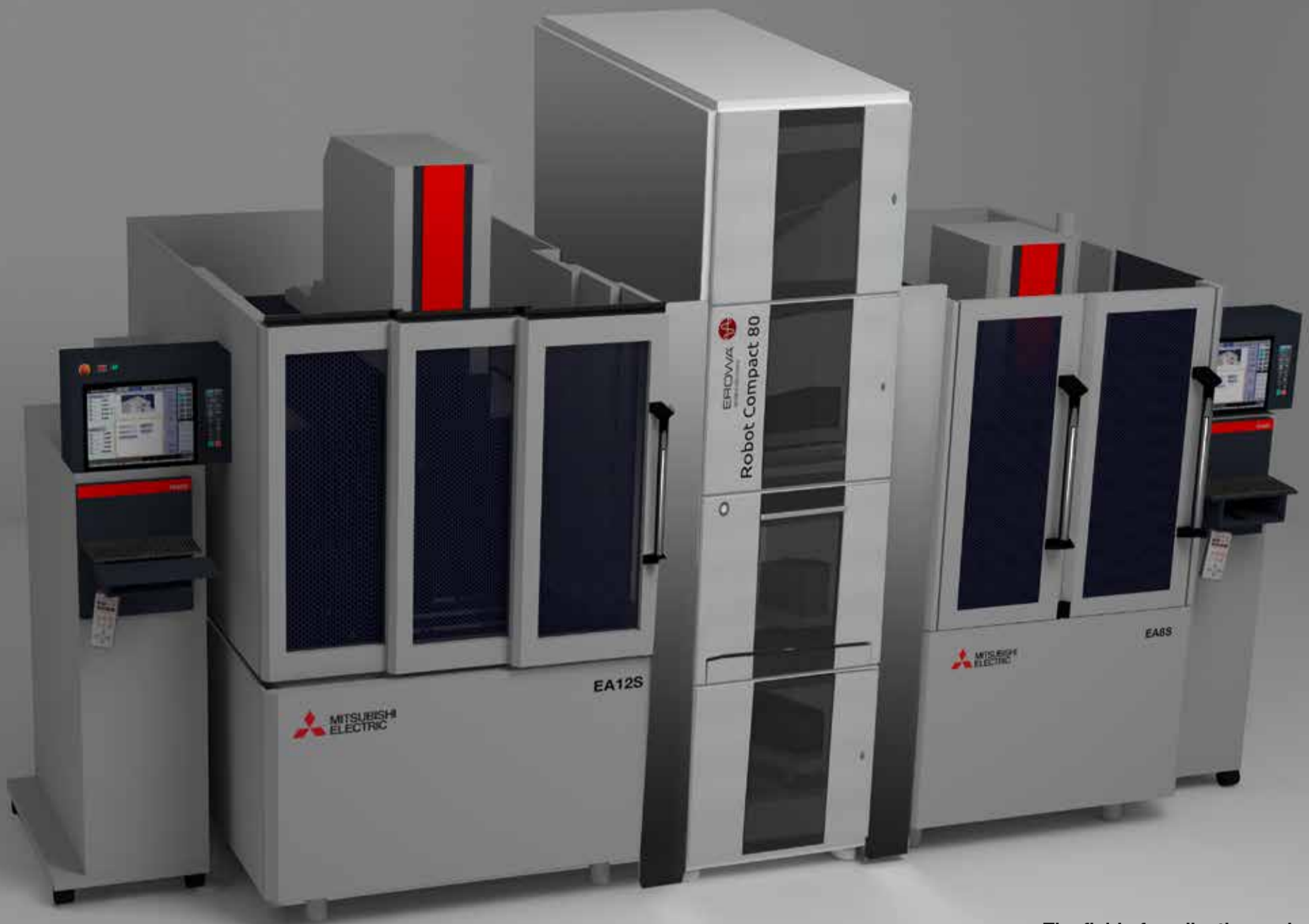

The field of application and range of uses determine the form of automation – everything's possible!

Automation has to be flexible.

Reconciling different brands.

Optimum solutions – customised, configured or standardised

The handling systems and robots from different manufacturers can often be seamlessly integrated. Renowned for their dependability and productivity, the EDM machines of the EA-S Series from Mitsubishi Electric are automation-ready. We'd be happy to show you examples that have proven effective in practice and help you to cut costs and boost your productive capacity.



Handling equipment from different manufacturers – welcome and easily integrated.



Flexible solution: Articulated-arm robot up to 15 kg of Mitsubishi Electric quality.

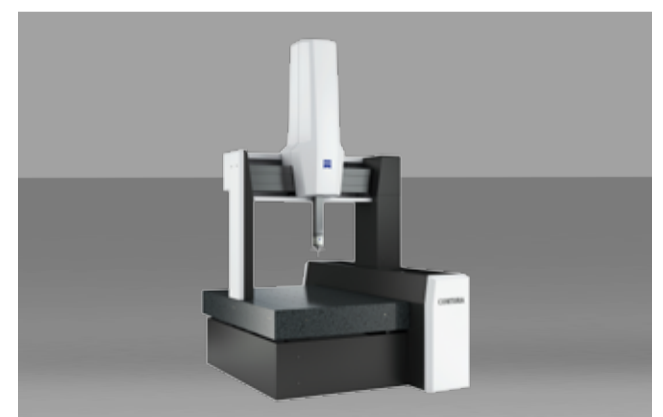

Economically advanced automation: External presetting by measuring workpieces and electrodes – beneficial with or without robotic handling.



Successfully mastered!

The success factor in a wide range of fields.

Medicine · Vehicle industry · Communications/electrics · Aerospace

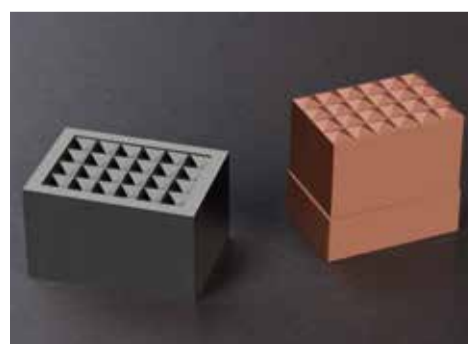
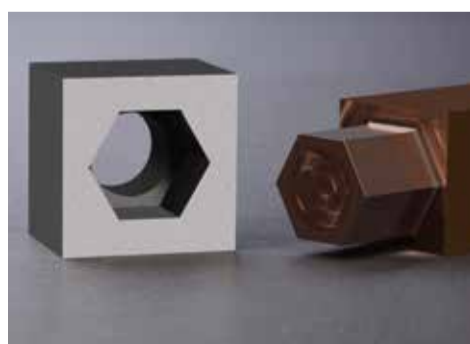
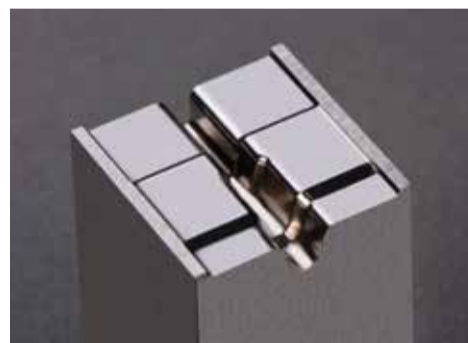
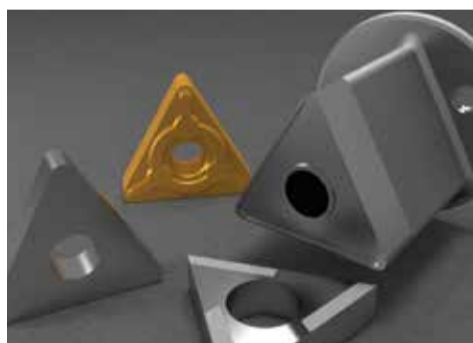

98.7%

of the spare parts available in Europe – delivery within 24 hours ex Düsseldorf warehouse

167,000

parts at the Düsseldorf warehouse

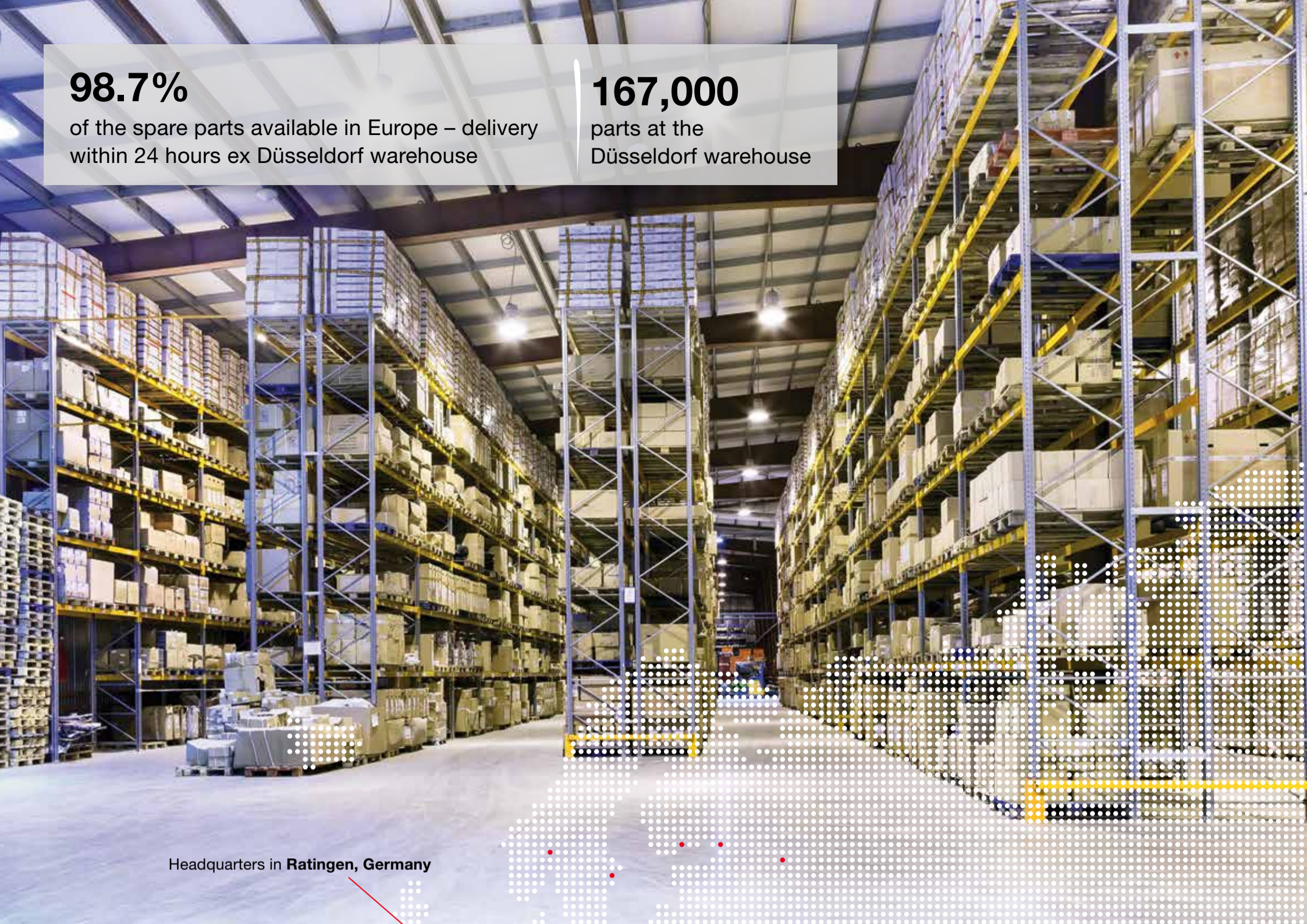

Headquarters in **Ratingen, Germany**

Service.
Always there.

Training

Users acquire skills at the machine and at specially equipped PC workstations. This way they benefit most from the direct transfer of know-how.

You don't like call centres and queuing systems? We don't either. With every Mitsubishi Electric EDM system you buy excellent service as part of the package.

With 167,000 parts in stock in Ratingen near Düsseldorf, you have a swift and reliable source of parts – on request by express in less than 24 hours. Service is performed by our own highly skilled service technicians so that production is kept dependably up and running.

Users are assisted over the phone and benefit from the expertise and wealth of experience of Mitsubishi Electric specialists.

Service hotline: +49 (0) 1801 486-600
Application support: +49 (0) 1801 486-700
Monday to Friday: 7.30 am to 8 pm
Saturday: 9 am to 4 pm

We're there to help you.



Expert assistance whenever I need it.



EA8S

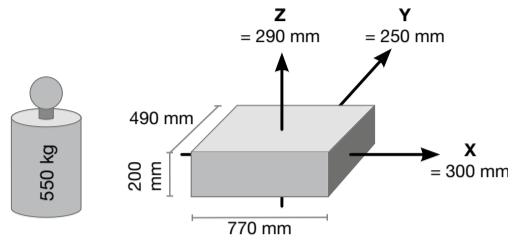

Machine body weight 2000 kg
 Generator weight 315 kg
 Machine height 2105 mm
 Required minimum dimensions for doorways(WxH) in mm 1505 x 2150 (LS-10T)/1730 x 2150 (LS-20T)

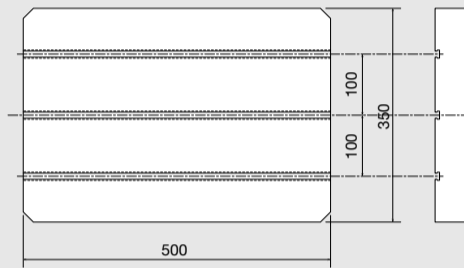
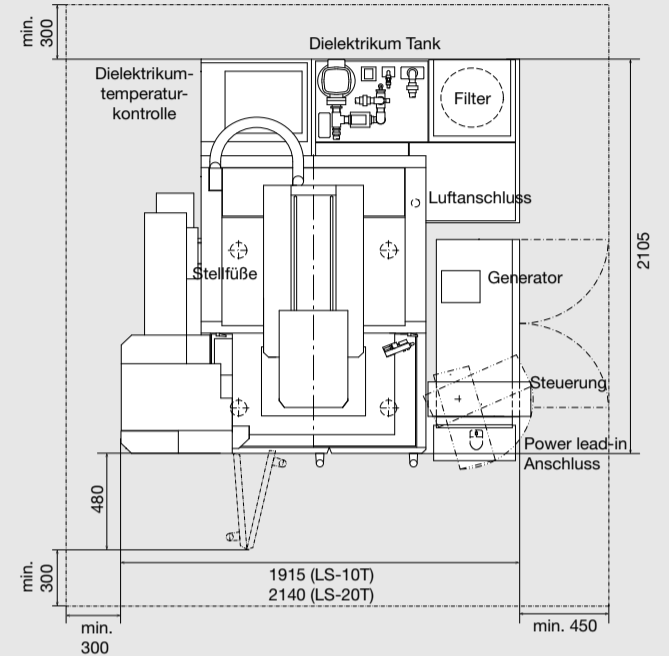
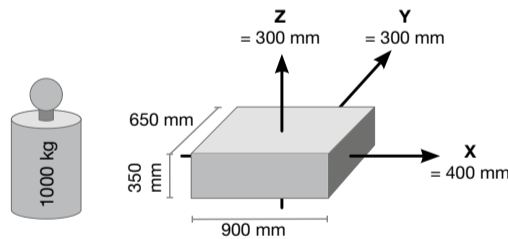

Table layout



EA12S



Machine body weight 3500 kg
 Generator weight 315 kg
 Machine height 2400 mm
 Required minimum dimensions for doorways (WxH) in mm 1900 x 2445

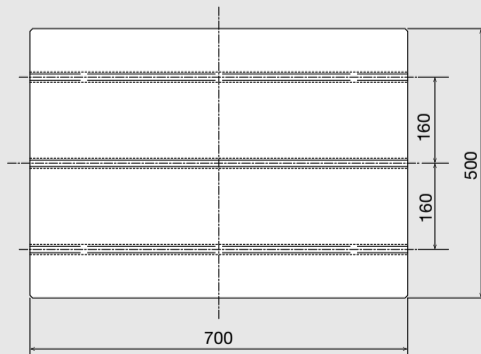
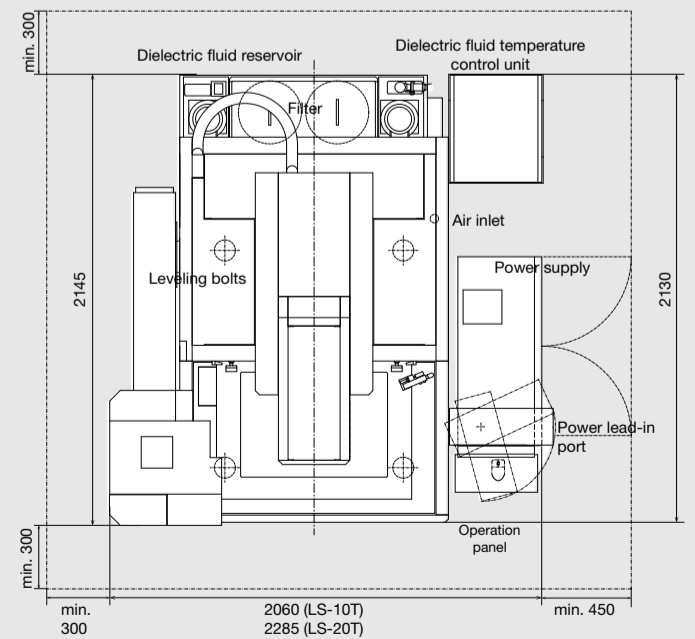
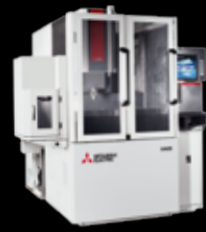





Table layout





	EA8S	EA12S	
Machine 	Travel (X/Y/Z) in mm	300 / 250 / 250	400 / 300 / 300
	Max. workpiece dimensions (W x D x H) in mm	770 x 490 x 200	900 x 650 x 350
	Max. workpiece weight in kg	550	1000
	Max. electrode weight in kg	25	50
	Table dimensions (W x D) in mm	500 x 350	700 x 500
	Table layout	Stainless steel table	
	Daylight (table – C-axis with EROWA chuck) in mm	150–400	200–500
	Max. dielectric filling level	250	400
	Magazine pockets	10	20
	Overall dimensions with tool changer (W x D x H) in mm	1915 (2140 with LS20) x 2000 x 2105	2285 x 2145 x 2400
	Machine weight in kg	2000	3500
	Mains voltage	3-phase 400 V/AC ± 10%, 50/60 Hz, 6,5 kVA	
Filter system 	Tank capacity in l	270	470
	Filter particle size in µm/Filter elements	3/1	3/2
	Temperature control	Dielectric cooling unit	
	Weight (dry) in kg	Included in machine weight	
Generator 	Power supply unit	Transistor-controlled pulse generator	
	Cooling method	Fully sealed/indirect air cooling	
	Max. output current in A	80	
	Dimensions (W x D x H) in mm	500 x 950 x 1770	
	Weight in kg	315	
Control 	Input method	Keyboard, USB flash drive, Ethernet	
	TFT colour monitor/Control system	15" touchscreen/CNC, closed circuit	
	Min. command step (X/Y/Z/U/V) in µm	0,1	
	Min. axis resolution in µm	0,05	

	EA8S	EA12S	
Equipment 	Three-sided elevating work tank	Yes	
	10-fold electrode changer	Yes	–
	20-fold electrode changer	–	Yes
	FP120S high-performance generator	–	Optional (not retrofittable)
	Ethernet/DNC/FTP	Yes	
	IDPM adaptive machining control	Yes	
	C-axis with EROWA chuck (1–30 rpm)	Yes	
	Hirschmann/3R chuck	Optional	
	mcAnywhere Control/Contact/Service	Optional	
	External signal output	Optional	
	Tricolour warning lamp	Optional	
	ERGO-LUX	Optional	
	Rotational axis	Optional	

Power connection: 3-phase 400 V/AC, PE, ± 10%, 50/60 Hz, primary fuse 40 A slow

Pneumatic connection: 5–7 kgf/cm³, 500–700 kpa, minimum air flow rate 60 l/min, 3/8" hose connection

The EDM system should be set up on a suitable hard industrial floor and preferably on a consolidated concrete floor. Any shielding that may be necessary in conformity with the EMC Directive is not included in the equipment supplied by Mitsubishi Electric.

The cooling unit contains fluorinated greenhouse gas R407C or R410A. For further information, please refer to the associated operating instructions.



Details can be found in the assembly plan of the machine:
www.mitsubishi-edm.de/download

Partner

Certified

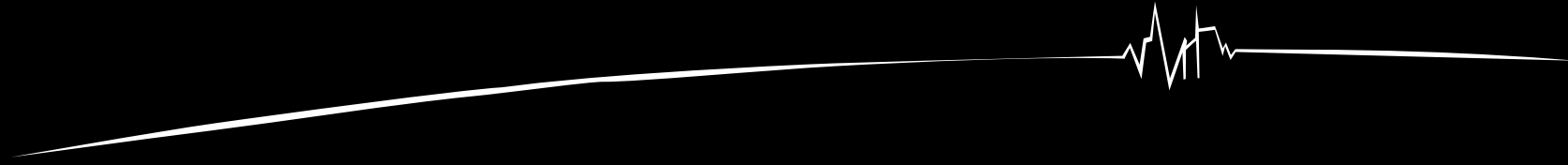

Subject to technical modification and error / 20.01.2016 / Art. No. 282590

EN

MITSUBISHI ELECTRIC EUROPE B.V.

Mechatronics Machinery / Mitsubishi-Electric-Platz 1 / 40882 Ratingen / Germany / Tel. +49 (0) 2102 486-6120 / Fax +49 (0) 2102 486-7090
edm.sales@mee.com / www.mitsubishi-edm.de

